

PRODUCT SPEC SHEET

E75 Food Waste Disposer



The premium range of food waste disposers



The E75 food waste disposer features a black and silver trim shell with a premium stainless steel sink stopper with a cover. It has a compact, space saving design. Supplied with three air switch buttons in chrome, matte black and brushed steel to integrate with modern finishes in your kitchen and is supported by a 5 year full in-home replacement warranty.



FEATURES

- Supplied with three air switch buttons - chrome, matte black and brushed steel
- 5 year full in-home replacement warranty
- New style trim shell
- Removable sound baffle
- Stainless steel grind elements
- Low water usage
- Continuous feed
- Powerful induction motor
- Overload protection
- Quick Lock® mounting assembly for faster, easier installation
- Cast lugs

DIMENSIONS (mm)

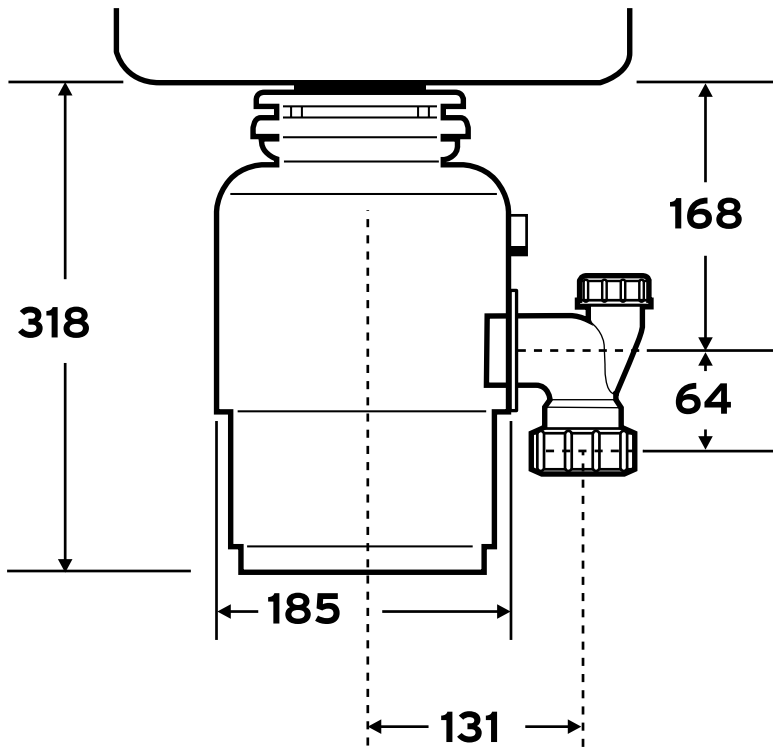

The air switch button is available in three colour choices.

Premium stainless steel stopper with cover.

SPECIFICATIONS

Type of feed	Continuous
On/Off Control	Wall switch or built-in air switch
Motor	Single phase
Reversing	None
Time Rating	Intermittent
Lubrication	Permanently lubricated upper & lower bearings
Shipping Weight (Approx.)	8.2kg
Unit Finish	Black
Overall Height	318mm
Grind Technology	1-stage grind technology
Grind Chamber Capacity	980ml
Motor Protection	Manual reset overload
Average Water Usage	Approximately 1% of household water consumption
Average Electrical Usage	3-4KWH per annum, equal to approximately \$3.50 per annum
Drain Connection	Yes
Dishwasher Drain Connection	No

Volts/Hz	HP	Average load
220-240V, 50-60Hz	.75 (@240V/50Hz)	405 W