

InSinkErator essentials



ES45

Food Waste Disposer

Features & Benefits

This model offers the following features and benefits:

- MAGNADRIVE 0.45 HP permanent magnet motor¹
- 1-Stage Grind: Reliable grind for everyday food scraps
- 3D Grind Zone: Engineered to quickly grind and rinse the disposal
- Lift & Latch technology for simplified installation
- Power cord attached for hassle-free outlet connections

The InSinkErator ES45 Food Waste Disposer has continuous feed, with 0.45 HP motor¹, galvanized steel grind components with two stainless steel lugs.

Warranty

1-year In-Home Limited Warranty²

Specifications

Type of Feed	Continuous
On/Off Control	Wall Switch (Not Supplied)
Motor	Single Phase
HP	0.45
Volts	220-240
HZ	50
Amp. (Avg. Load)	3A
Time Rating	Intermittent

Lubrication	Permanently Lubricated Upper & Lower Bearings
Shipping Weight (Approx.)	5.5 kg
Overall Height (Approx.)	35.3 cm
Motor Protection	Unplug to Reset
Dishwasher Drain Connection	No

Dimensions

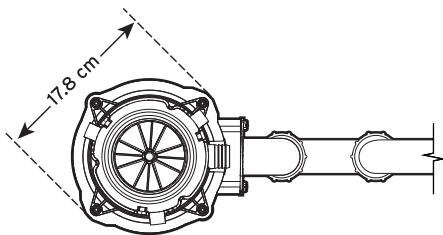
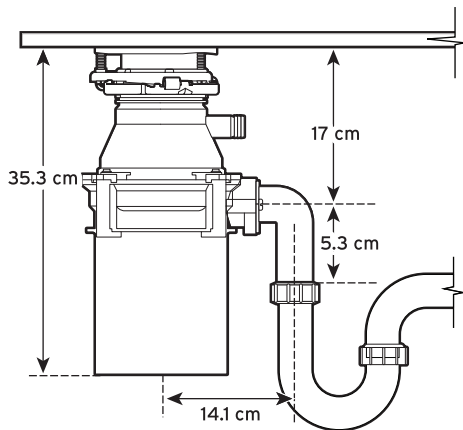

¹ Laboratory measurement of peak horsepower output of motor, not the operational output at the disposal.

² Visit www.insinkerator.com.au/home-full-service-limited-warranty for warranty details.



Warning
Observe local authority Installation restriction



Food waste is roughly 65-90% water. By using your disposal regularly, you can help divert food waste from landfills and reduce greenhouse gas emissions. Make sustainability a family affair by using your disposal. After all, the smallest changes can make the biggest impact.

1300 136 205
www.insinkerator.com.au